

MINI CABLE HOIST - MINI-4

APPROX WEIGHT: 36.3 lbs.
DOES NOT INCLUDE WEIGHT OF POWER OR PACKAGING!!!

*** ANY ADDITIONS, DELETIONS, OR OMISSIONS MUST BE CORRECTED ON THIS DRAWING AS THIS DRAWING WILL BE CONSIDERED ALL INCLUSIVE ***
ALL GRAPHICS PROVIDED ARE FOR REFERENCE ONLY. IF CERTAIN DIMENSIONS ARE CRITICAL PLEASE VERIFY THOSE DIMENSIONS WITH YOUR SALESPERSON

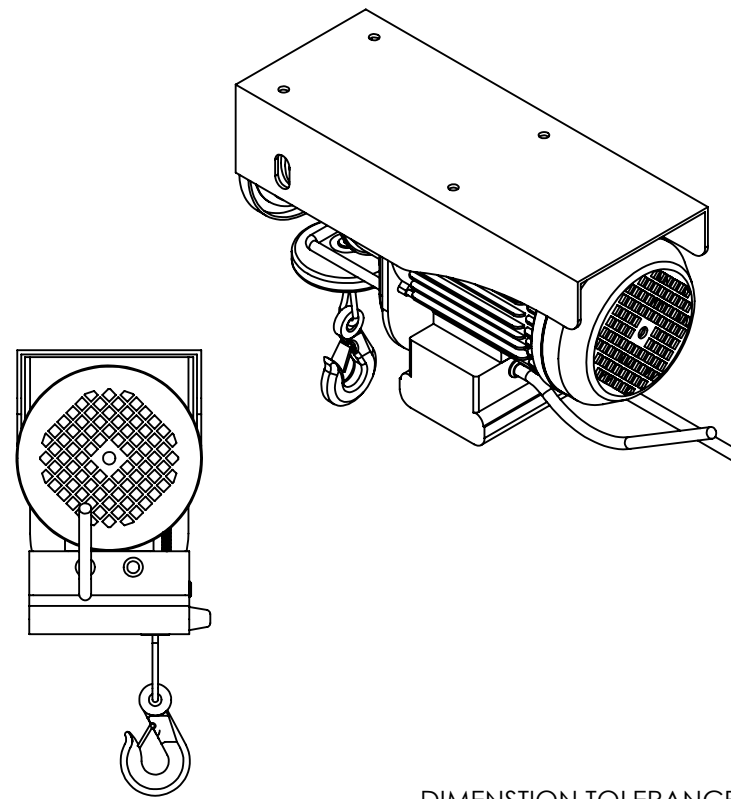
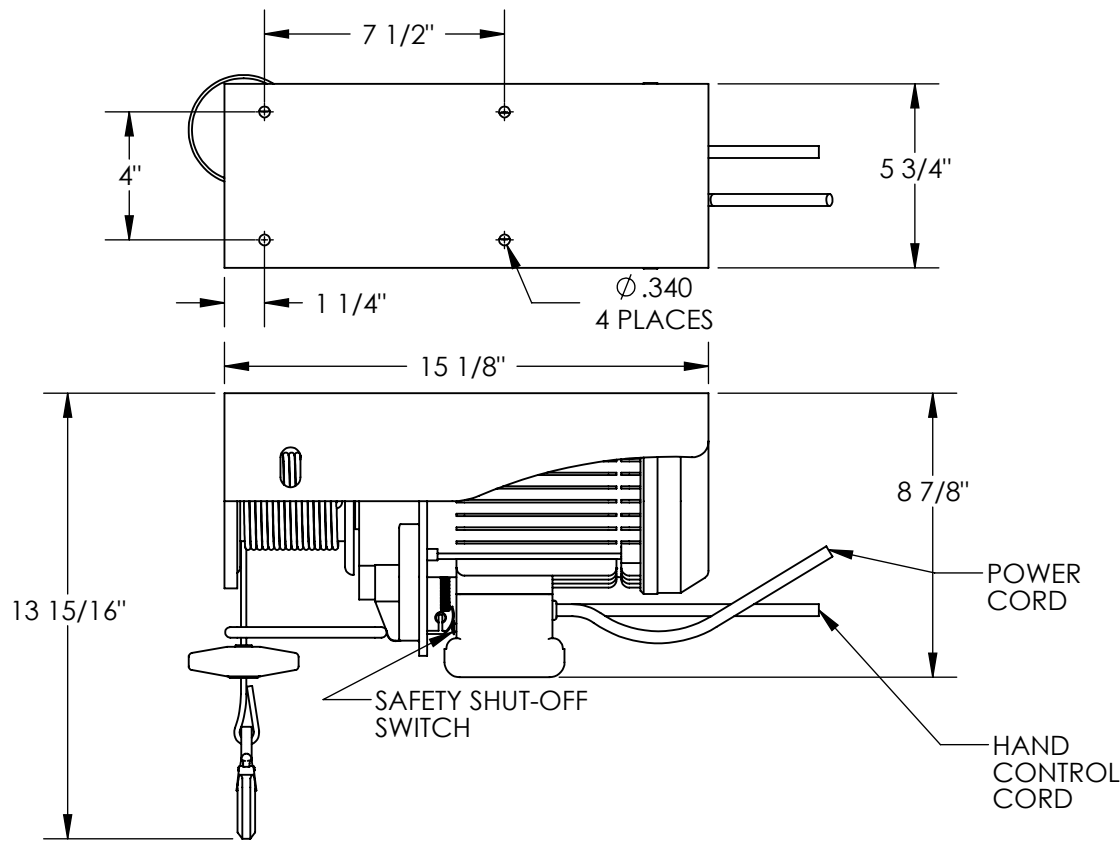

DIMENSION TOLERANCE $\pm 1/4$ "

STANDARD FEATURES

MODEL NUMBER IS MINI-4
OVERALL WIDTH IS: 5 3/4"
OVERALL LENGTH IS: 15 1/8"
HEIGHT IS: 8 7/8"
MAX. UNIFORM SINGLE-LINE CAPACITY: 400 LBS.
MAX. UNIFORM DOUBLE-LINE CAPACITY: 800 LBS.
LIFTING SPEED (PER MINUTE): 30'
115VAC, 1-PHASE, 60HZ

SPECIAL FEATURES

NONE

APPROVAL	I, THE UNDERSIGNED, AGREE THAT THE PRODUCT AS REPRESENTED SATISFIES DESIGN AND DIMENSION REQUIREMENTS. I ALSO ACKNOWLEDGE MY DUTY TO CONFIRM PRODUCT AND INSTALLATION COMPLIANCE WITH ALL APPLICABLE FEDERAL, STATE AND LOCAL REGULATIONS AND STANDARDS.	
	UNITS REQUIRING APPROVAL DRAWINGS OR MODIFIED ARE NON-RETURNABLE	
	[] As drawn	[] As marked
	Signed: _____	Date: _____
	Printed Name: _____	
	<i>LEAD TIME WILL START UPON RECEIPT OF SIGNED APPROVAL DRAWING</i>	

DISTRIBUTOR'S NAME:		P.O.#
VESTIL MANUFACTURING		X
DRAWN BY: TJM		W.O.#
DATE: 12/29/09		X
REFERENCE: X	SCALE: 1:6	SALES: X
QUOTED LEAD TIME: X	QUOTE #	FILE NAME:
	X	28-007-044